

Menara and Menara Grande Pendants

LP891_, LP890_ 1.0



Suspension

GENERAL PRODUCT INFORMATION:



This product is suitable for damp locations.



Assemble the Pendant

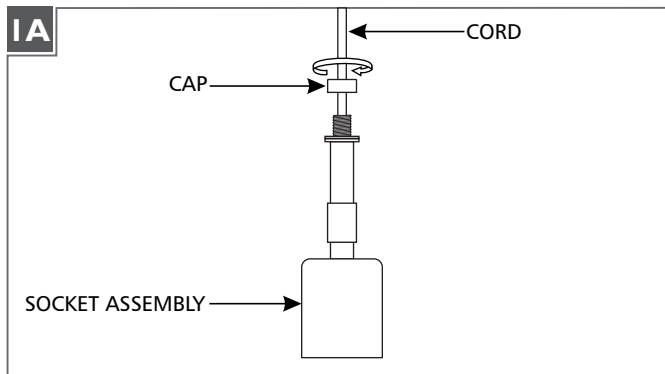

1 Unscrew and remove the fixture cap from the socket assembly and cord.

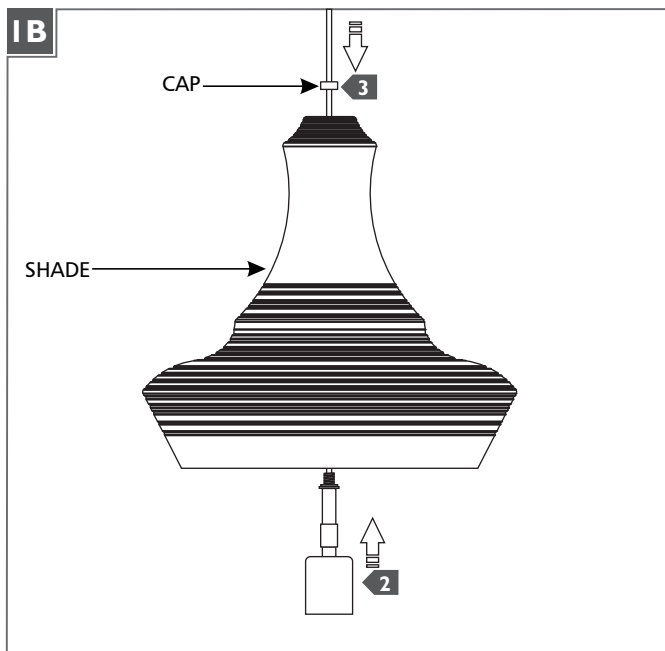

2 Ensure that the washers are in place and feed the fixture cord through the shade.

3 Reinstall the cap onto the cord.

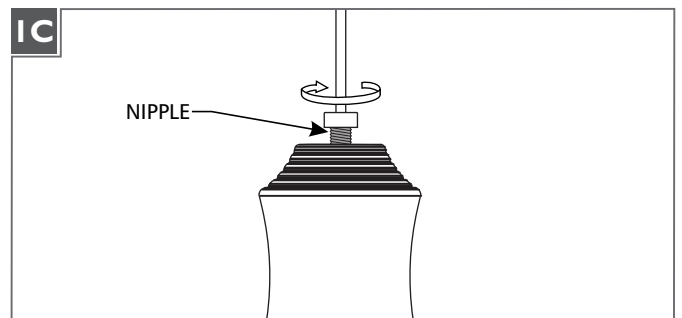

1 Insert the socket assembly nipple through the top of the shade and secure it in place with the cap.

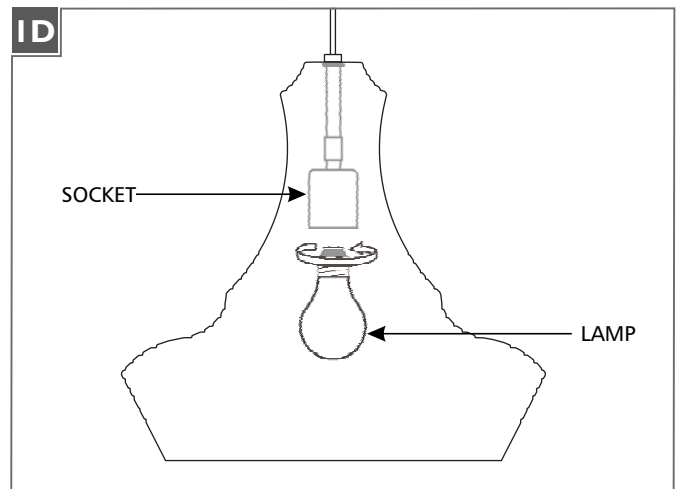

CAUTION: To reduce the risk of a burn or electric shock during re-lamping, disconnect the power to the fixture.

Refer to fixture marking for lamp information.

1 Screw the lamp into the socket.

SAVE THESE INSTRUCTIONS!

LBL

7400 Linder Ave, Skokie, IL 60077

800.323.3226 - 847.626.6300

www.lblighting.com

© 2016 LBL Lighting. All rights reserved. The "LBL Lighting" graphic is a registered trademark of LBL Lighting. LBL Lighting reserves the right to change specifications for product improvements without notification.

A Generation Brands Company