

Stratos Chandelier

LED T20

DESCRIPTION

The overlapping panes of gently curved glass instantly define the Stratos LED chandelier from Tech Lighting. The collection of slumped transparent or frosted glass combine to create a shade which surrounds a smoothly diffused, fully dimmable LED source, all within an ultra-slim profile. Two diameter options of 24in and 30in, plus a coordinating Stratos wall sconce light enable this modern lighting collection to be scaled from residential dining room lighting, kitchen island lighting and media room lighting applications to commercial hospitality lighting and corporate lighting applications. 24IN includes 120-277 universal voltage, 30 watt, 1900 delivered lumen, 2700 LED module. Dimmable with low-voltage electronic, triac or 0-10v dimmer. 30IN includes 120-277 universal voltage, 50 watt, 3142 delivered lumen, 2700K LED module. Dimmable with low-voltage electronic, triac or 0-10v dimmer. Fixture provided with twelve feet of field-cutable cable.

INSTALLATION

This product can mount to either a 4" square electrical box with round plaster ring or an octagonal electrical box (not included).

WEIGHT

6.0-6lb / 2.72-2.72kg ±

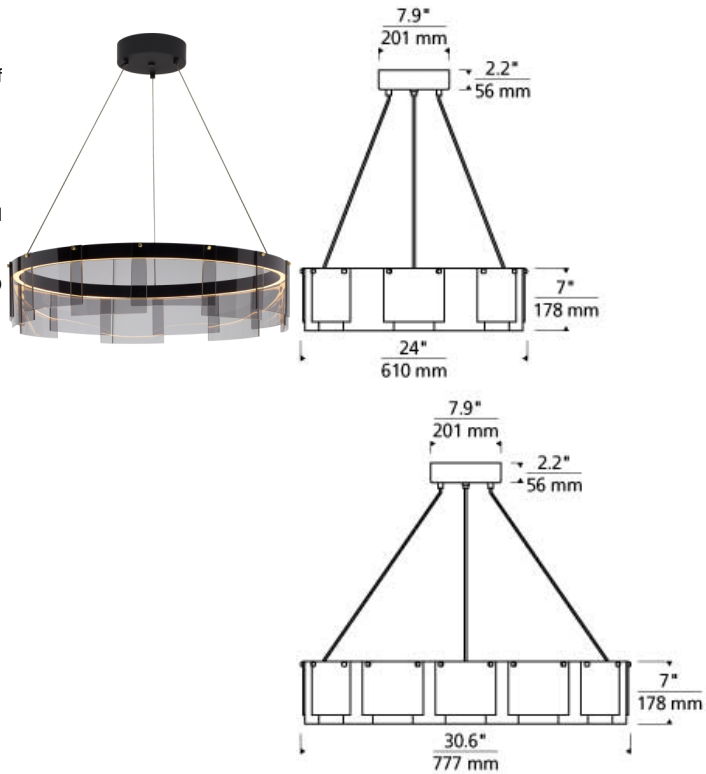

frost / satin nickel 24"
smoke / black 30"

ORDERING INFORMATION

700STR	SHAPE OR SIZE	COLOR	LAMP
24	24" DIAMETER	FS FROST/SATIN NICKEL	-LED927 LED 90 CRI 2700K 120V
30	30" DIAMETER	KB SMOKE/BLACK	



TECH LIGHTING®

7400 Linder Avenue T 847.410.4400
Skokie, Illinois 60077 F 847.410.4500

Tech Lighting, L.L.C.

700 STR _____

FIXTURE TYPE: _____

JOB NAME: _____

NOTES: _____

